

**Single arm davit system, type RhsL 21/3,6
for
rescueboat and 25 person liferaft**

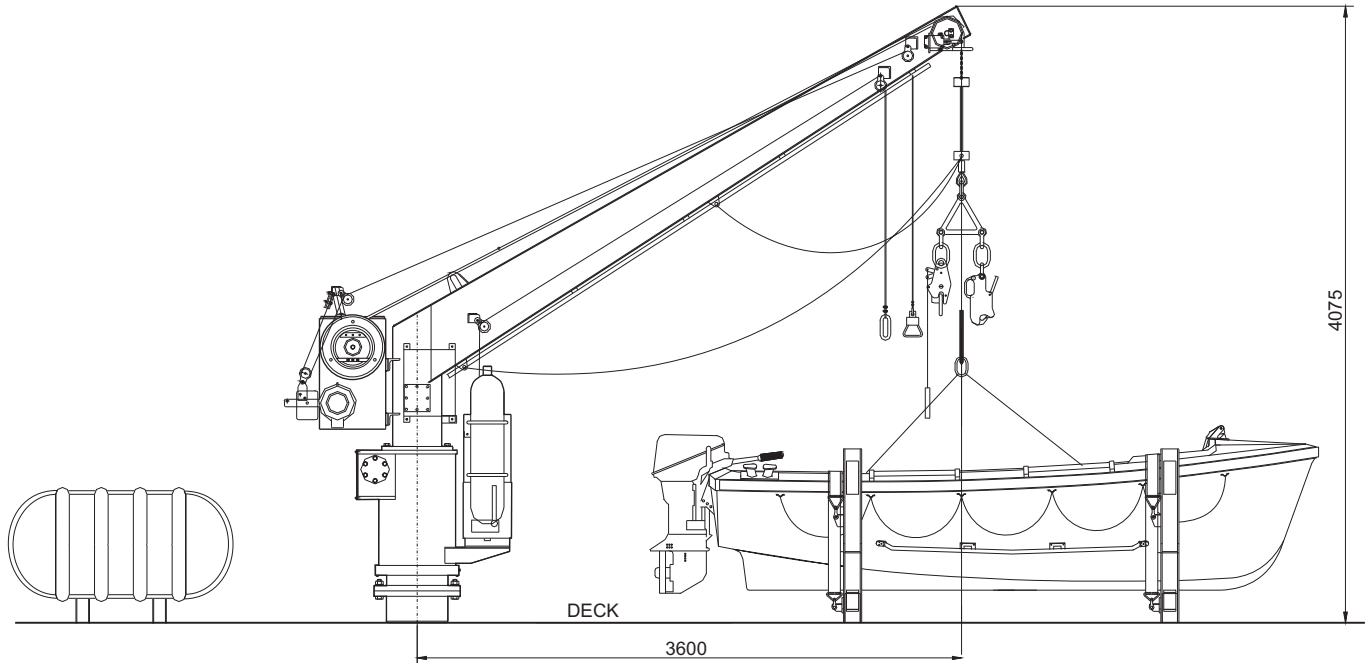

Scale 1:50

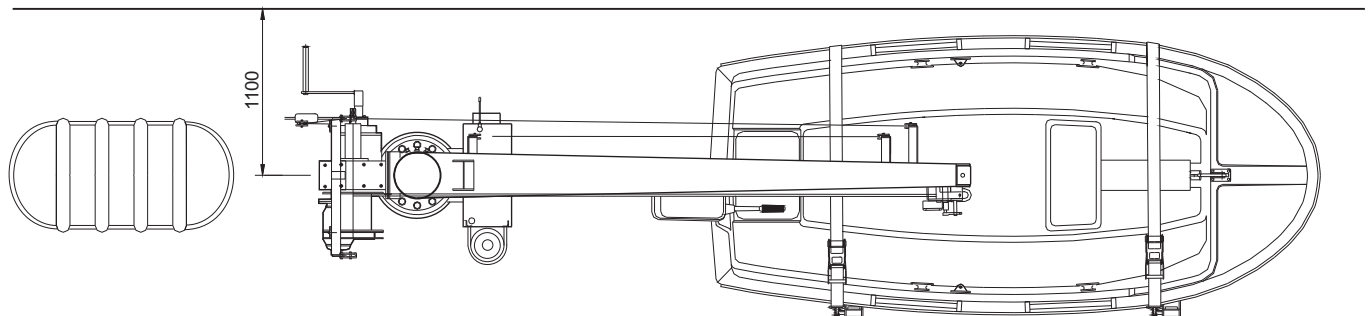

Technical Data of the RhsL 21/3,6

Davit Main Data

SWL	21 kN
Outreach	3,6 m
Hoisting Speed	18 m/min
Lowering speed	0,4 + (0,02 x H) m/s
Slewing Speed.....	abt 0,5 rpm
Voltage	380 / 440 V
Frequency	50 / 60 Hz
Total mass of davit system.....	1600 kg

Rescueboat Main Data

Boat type.....	RB 400
Dimensions overall	4,00 x 1,80 x 0,70 m
Weight of boat with equipment	435 kg
Lowering / hoisting weight.....	885 kg

Liferaft Main Data

25 persons davit launched type	
Weight of liferaft with equipment	225 kg
Lowering weight (max.)	2100 kg